



Portable Plants

WG220E

Wheeled Cone Plant



A world working better™

Portable Plants

WG220E

Wheeled Cone Plant

The Terex WG220E is a Portable Cone Crusher designed primarily for the European market. This high-performance Cone plant is suitable for secondary or tertiary processing in hard rock quarries and gravel pits, producing aggregates for construction. This plant incorporates the Cedarapids TG220 Cone crusher. These impressive cone crushers can be easily and efficiently set up to perform and deliver the best cost per ton cubicle product by selecting the optimum crushing cavity and eccentric throw to suit the application requirements.

Applications	
Sand & Gravel	C & D Processing
Blasted Rock	Overburden
River Rock	Mineral Ores

Features & Benefits

- Powerful Crushing: Ideal for secondary/tertiary hard rock processing
- Easy plant set up with hydraulic telescopic legs
- Complies with European road regulations for truck transportation
- Multiple discharge conveyor positions can fit with existing mobile crushing setups
- Electric Drive
- 1000mm wide discharge conveyor
- 5m³ hopper and 1000mm variable speed belt feeder
- Ultrasonic sensor fitted at the cone hopper ensures smooth continuous feed rate
- Cone crusher AIC system automates the cone crusher adjustments to give optimal performance
- Inspection platforms foldable for transport
- Plant electrical switchgear panel

5m³ hopper capacity with foldable wings to feed with front end loader

Stairway access to magnet, metal detector and cone for leading

Cone Feed hopper overflow chute can be fitted in three directions to match discharge conveyor

TG220 Cone Crusher with 160kW motor

Access walkways all around crusher, foldable for transport

1000mm wide discharge belt can be positioned; left, right, front

1000mm wide variable speed belt feeder with 11kW motor

Triple axle chassis complies with European road regulations for truck transportation

Hydraulic Legs for leveling and operation



Options

- Permanent magnet on the feed conveyor
- Belt scale on the feed conveyor

Power:	
Cone Crusher	160kW
Feed Conveyor	11kW
Discharge Conveyor	7.5kW

Operating Mode

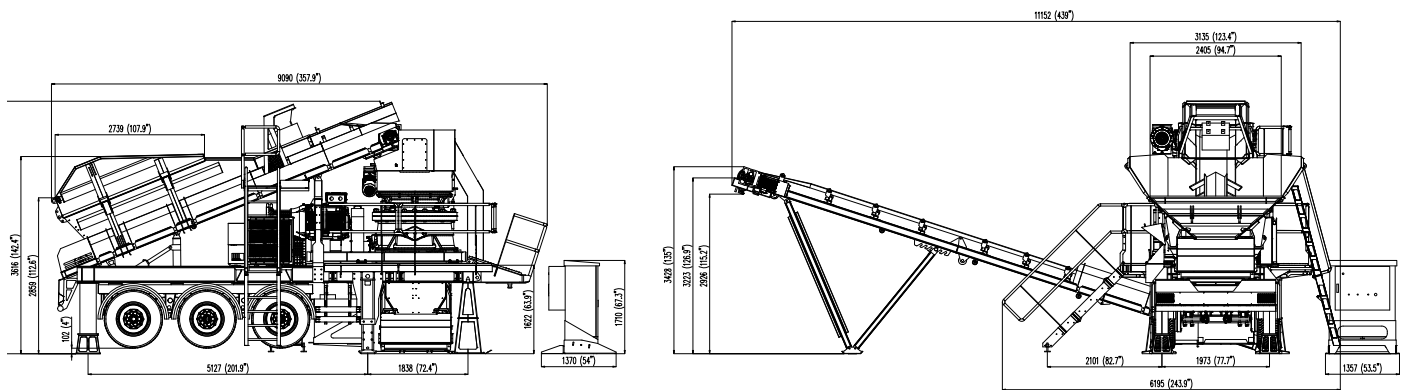

Transport Mode

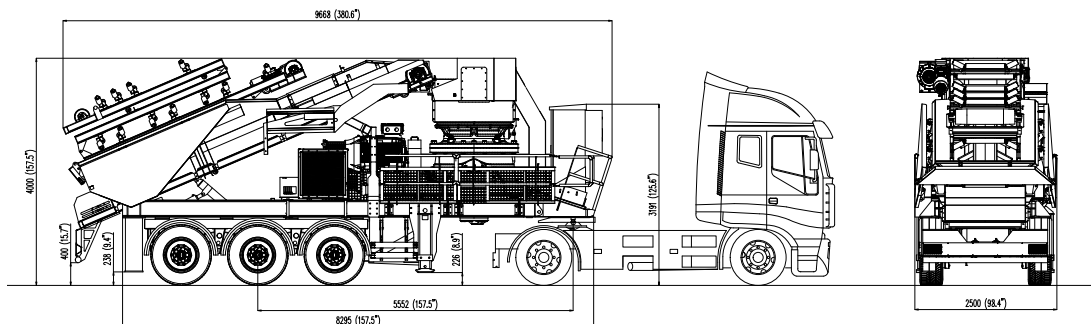

Weight:

- Transport Weight:
 - Total weight : 32, 200kg (70 ,990lb)
 - King pim weight: 11, 050kg (24, 360lb)
 - Axle weights: 21, 150kg (46, 630lb)
- Working weight (discharge conveyor removed): 29, 830kg (65, 770lb)

North America

3900 Fountains Blvd NE, Suite 101
Cedar Rapids, IA 52411
Tel: +1 319 363 3511 or
+1 800 821 5600

212 South Oak Street
Durand, MI 48429
Tel: +1 989 288 3121 or
+1 888 571 8352

Europe, Russia & Africa

Farlough Road, Dungannon
Northern Ireland. BT71 4DT
Tel: +44 (0) 28 8744 0795

Central Asia, Turkey & North Africa Region

Mehmet Akif Ersoy Mah.287.Sk
No 1/D
06172 Yenimahalle - Ankara Turkey
Tel: +90 312 354 90 90

Australia

Melbourne & Victoria
133 Logis Boulevard
Dandenong South, VIC 3175
Tel: +61 3 8794 4100

Sydney & New South Wales
114 Hassall Street
Wetherill Park, NSW 2164
Tel: +61 2 9604 6524

Brisbane & Queensland
585 Curtin Avenue East
Eagle Farm, QLD 4009
Tel: +61 7 3630 0866

Perth & Western Australia
4 Miles Road
Kewdale, WA 6105
Tel: +61 8 6254 4100

UAE

Middle East, East Africa, and SE
Asia
Office # 305, Pinnacle Building
Sheikh Zayed Road, Al Barsha 1,
Dubai, UAE
Tel: +971 4 399 0381

India

South: Hosur Plant
Terex India Private Limited
Plot No : E-18, Expansion-II, Phase-II
SIPCOT, Krishnagiri Road
Hosur - 635 109, Tamil Nadu
Tel: +91 4344 352 200

West

Terex India Private Limited
Office No. 05-116, Zenia Building
Hiranandani Circle,
Hiranandani Business Park
Thane - 400607, Maharashtra
Tel: +91 4344 352 200

North

Terex India Private Limited
907-908, 9th Floor,
Palm Spring Plaza, Golf Course
Road, DLF Phase 5, Sector 54
Gurgaon 122 003, Haryana
Tel: +91 4344 352 164

Malaysia

Malaysia Sdn Bhd
Lot 53674, Persiaran Subang Indah
Sungei Penaga Industrial Estate
47610 Subang Jaya
Selangor, Malaysia
Tel: +60 356 226 199
Email: Sales.Sea@terex.com

Thailand

Terex (Thailand) Limited
999/162 Moo 15,
Bangsaothong Sub-District
Bangsaothong District
Samutprakarn 10570
Tel: +66 2130 6381
Tel: +66 2130 6382

MPSPMarketing@terex.com

www.terexmps.com

Product specifications and prices are subject to change without notice or obligation. The photographs and/or drawings in this document are for illustrative purposes only. Refer to the appropriate Operator's Manual for instructions on the proper use of this equipment.

Failure to follow the appropriate Operator's Manual when using our equipment or failure to act responsibly may result in serious injury or death.

The only warranty applicable to our equipment is the standard written warranty applicable to the particular product and sale, and Terex makes no other warranty, express or implied. Terex, the Terex Crown design, Cedarapids, Canica, Simplicity, Jaques, El-Jay and Rollercone are trademarks of Terex Corporation or its subsidiaries. All rights are reserved. © July 2024

